

KLT-MAA29-S5K3P8 V1.0

16MP Samsung S5K3P8 MIPI-Schnittstelle Autofokus Kameramodul



Vorderansicht



Rückansicht

Spezifikationen

Kameramodul Nr.	KLT-MAA29-S5K3P8 V1.0
Auflösung	16MP
Bildsensor	S5K3P8
Sensorart	1/3.1"
Pixel Größe	1.0 um x 1.0 um
EFL	3.81 mm
F.NO	2.20
Pixel	4640 x 3488
Betrachtungswinkel	76.8°(DFOV) 62.7°(HEOV) 48.7°(MFOV)
Linsenabmessungen	8.50 x 8.50 x 5.60 mm
Modulgröße	20.85 x 8.50 mm
Modultyp	Autofokus
Schnittstelle	MIPI
Autofokus-VCM-Treiber-IC	CN3927E
Linsenmodell	KLT-LENS-60183A1
Linsentyp	650 nm IR-Schnitt
Betriebstemperatur	-30°C to +70°C
Gegenstecker	BBR43-30KB533

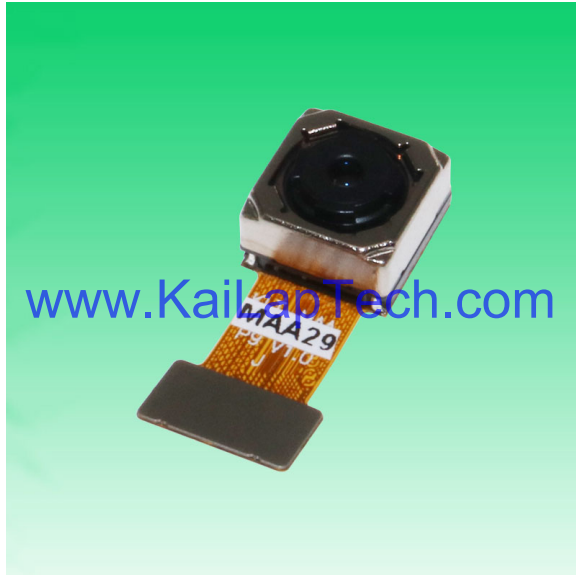
**KLT-MAA29-S5K3P8 V1.0****16MP Samsung S5K3P8 MIPI-Schnittstelle Autofokus Kameramodul**

Ansicht von oben

www.KaiLapTech.com

Seitenansicht

www.KaiLapTech.com

Untersicht

www.KaiLapTech.com

Gegenstecker

www.KaiLapTech.com

Version	Information	Date
V1.0	First Version	4-24-2022

RoHS	
0	SIGNAL
1	GND
2	GND
3	GND
4	GND
5	AFVDD2.8V
6	NC
7	SDA
8	DOVDD1.8V
9	SCL
10	DVDD1.0V
11	GND
12	XSHUTDOWN
13	MCN
14	NC
15	MCP
16	GND
17	MDO0N
18	MCLK
19	MD0P
20	GND
21	MD1N
22	FLASH
23	MD1P
24	AVDD2.8V
25	NC
26	AGND
27	MD2N
28	MD3N
29	MD2P
30	MD3P

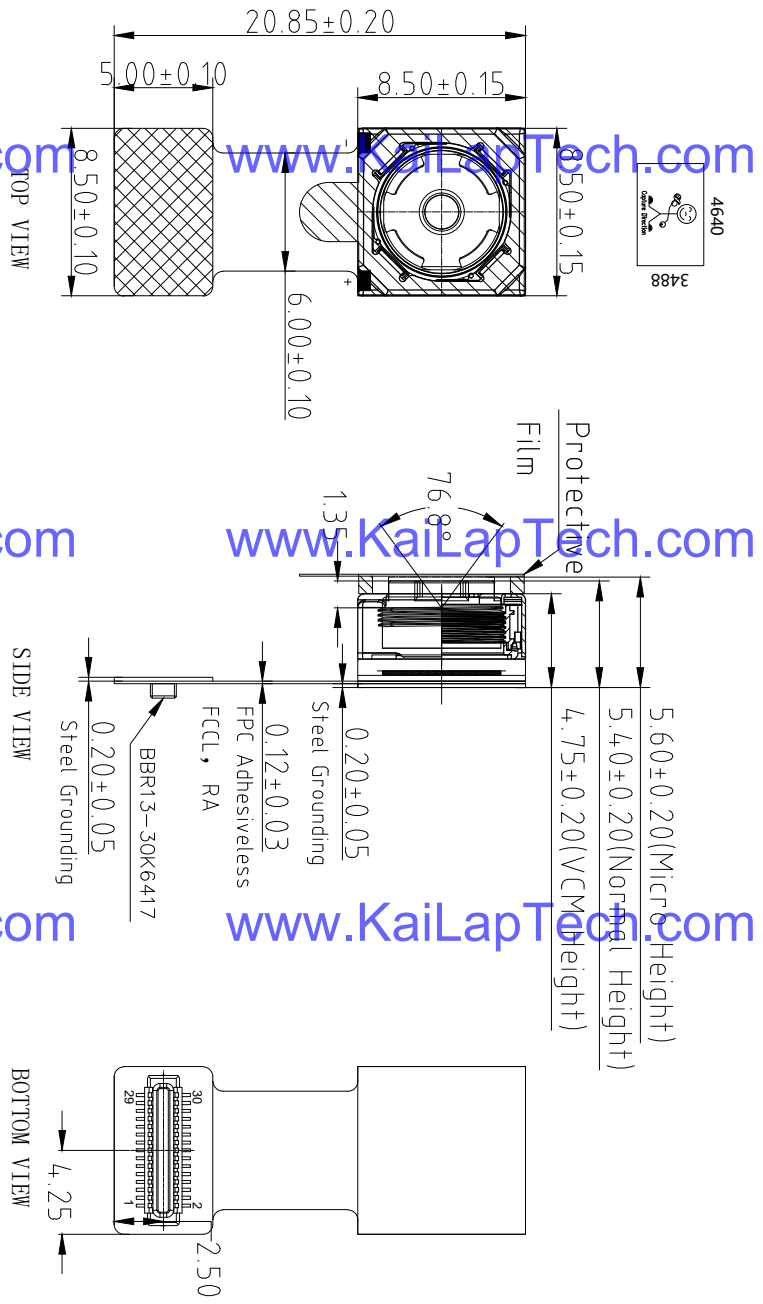

NOTE:

1.The device slave address:0x20;

Parameters:

1、Sensor specification:

Image Sensor: S5K3P8
 Pixel: 1.0umx1.0um
 Lens Type: 1/3.1
 Important Voltage Description: DVDD1.0V (external power supply);

2、Lens specification:

FOV: 76.8°(D),62.7°(H),48.7°(V);
 F/No: 2.2
 TV Distortion: <1.5%
 Focal length: 3.81mm
 Composition: 6P+IR FILTER
 IR Cut Coating: 650nm±10nm@50%

Kai Lap Technologies Group Ltd

Designed By	Kelin	Model Name:	KLT-MAA29-S5K3P8 V1.0		
Checked By	Aouly_Yan	Projection Type:	Unit:	Material:	Version:
		Third Angle	mm	-----	1/0
			Scale:	Sheet:	Version:
			1:1	1 of 1	1/0



Lens Model: KLT-LENS-60183A1

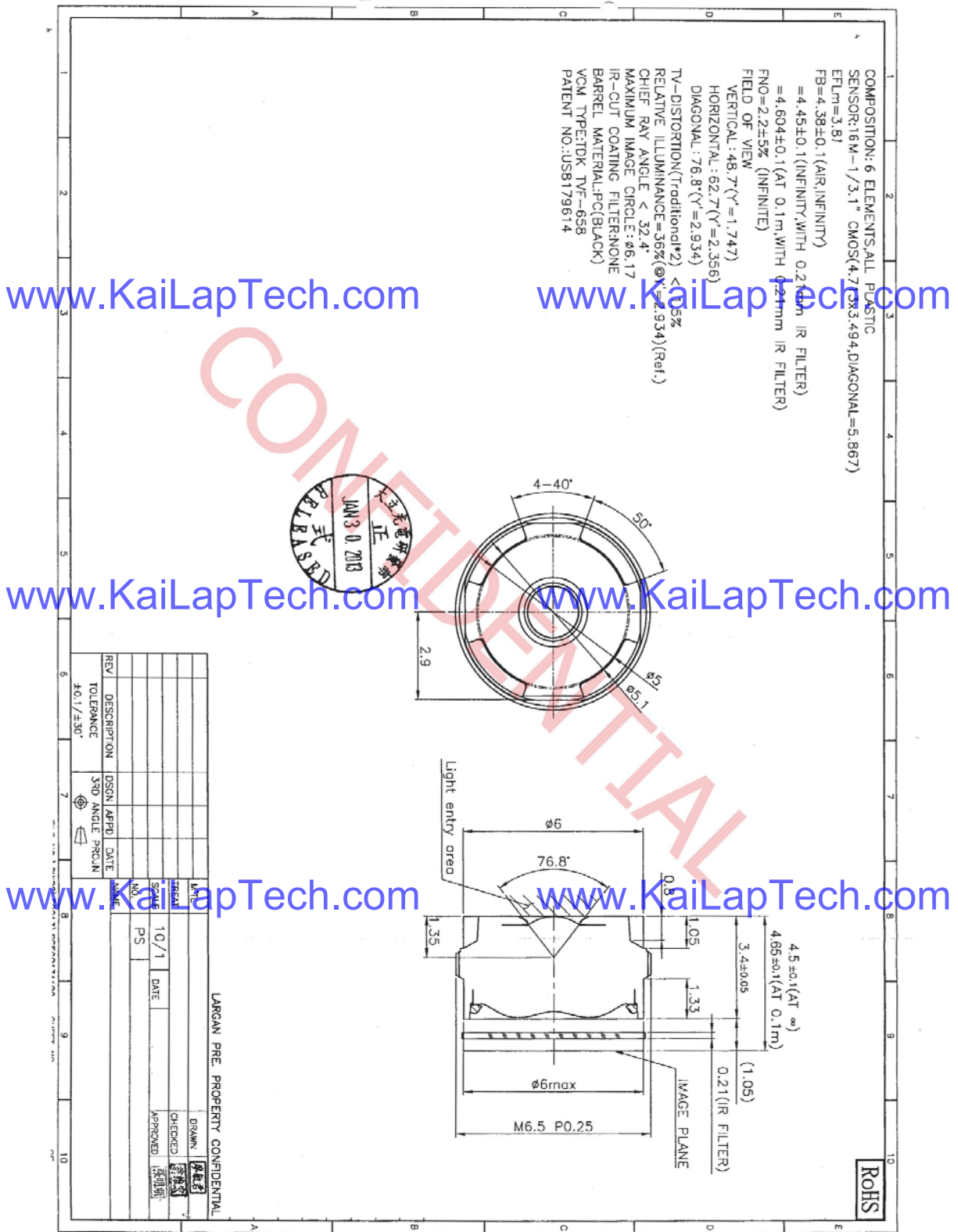

CN3927E

Low Cost Voice Coil Motor Driver with I2C interface

1. Description

The CN3927E is a low cost single 10-bit DAC with 120mA output current sink capability. Designed for linear control of voice coil motors, the CN3927E is capable of operating voltage from 2.3V to 5.5V. The DAC is controlled via a I2C serial interface that operates DAC by clock rates up to 400kHz.

The CN3927E incorporates with a UVLO reset circuit, power-down function, and exactly matched sense resistor. UVLO reset circuit ensure when supply power up, DAC output is to 0V until valid write-bit value takes place. It has a power down features that reduces the current consumption of the device to 1uA maximum.

The CN3927E is designed for auto focus and optical zoom camera phones, digital still cameras, and camcorders applications. The I2C address for the CN3927E is 0x18.

Features

- WLCSP package for minimum footprint
- Ramp control circuit
- Fixed I²C logic thresholds
- 10-bit D-to-A converter
- 117μA *I*_{out} resolution
- I2C serial interface (1.8V input available)
- Low current sleep mode
- 2.3 to 5.5 V power supply

Applications

- Digital camera
- Cell phone
- Lens auto focus
- Web camera

Package:

- 6-Bump Chip Scale Package
- 0.70mm (W) x 1.10mm (H) x 0.28mm (T)
- 0.4mm Bump Pitch



2. Functional Block Diagram

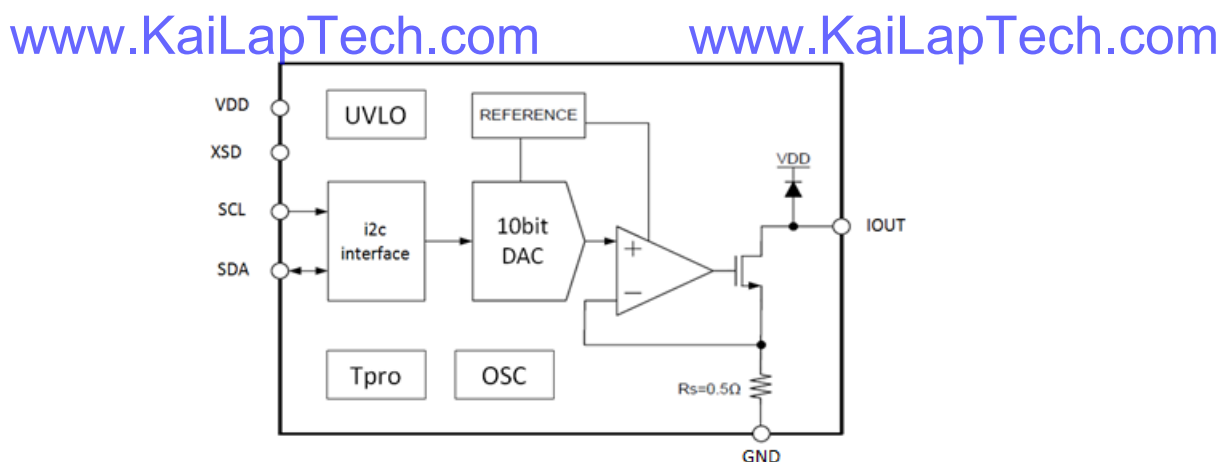

3. Pin Assignments

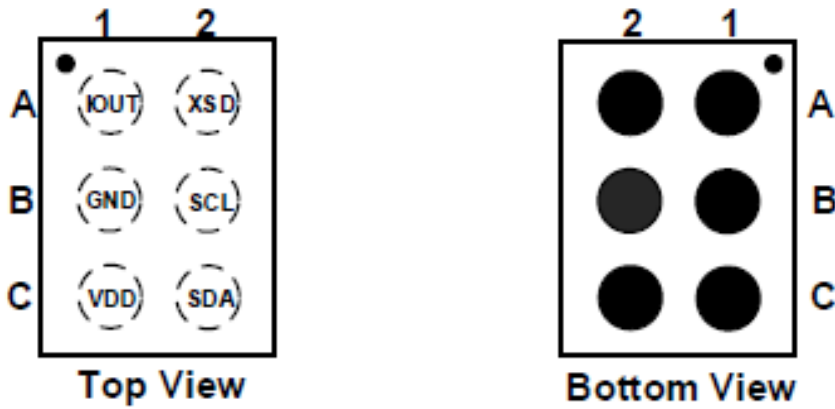

www.KaiLapTech.com

www.KaiLapTech.com

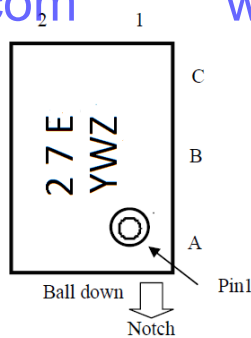

www.KaiLapTech.com

www.KaiLapTech.com

Top Mark

4. Pin Description

Pin Name	Pin Number	Description
IOUT	A1	Sink Drive Output
XSD	A2	Standby Mode Control
GND	B1	Ground
SCL	B2	I ² C clock
VDD	C1	Power Supply In
SDA	C2	I ² C data

www.KaiLapTech.com

www.KaiLapTech.com

5. Ordering Information

Order Part Number	Top Marking	Pb-Free	T _A	Package	
CN3927E	27E	Yes	-40 to +85°C	WLCSP6	Tape & Reel, 3K

6. Absolute Maximum Ratings

Stresses beyond those listed under “Absolute Maximum Rating” may cause permanent damage to the device. These are stress ratings only and functional operation of the device at these or any other condition beyond those indicated in the operational sections of the specifications is not implied. Exposure to absolute maximum rating conditions for extended periods may affect device reliability.

Parameter		Conditions	Min.	Typ	Max.	Unit
Supply Voltage	VDD				6.5	V
Logic Input Voltage Range	Vin		-3		Vdd+0.3	V
Junction Temperature	Tj				150	°C
Storage Temperature Range	Ts		-40		150	°C
Operating Temperature Range			-40		85	°C
ESD (HBM)				6		KV
CN3927E	Rja	4 layer PCB			64	°C/W

7. Recommend Operating Conditions

The Recommended Operating Conditions table defines the conditions for actual device operation to ensure optimal performance to the datasheet specifications. CHIPNEXT does not recommend exceeding them or designing to Absolute Maximum Ratings.

Parameter	Min.	Typ.	Max.	Unit
Supply Input Voltage	2.3	3	5.5	V
Junction Temperature Range	-40		125	V
Ambient Temperature Range	-40		85	°C

8. Electrical Characteristics

T_A = 25°C, VDD=2.8V, (unless otherwise specified)

Characteristics	Symbol	Test Conditions	Limits			
			Min.	Typ.	Max	Units
Supply Current	Ivdd	Code=0		0.2		mA
		Sleep Mode (XSD=Low),			1	uA
		Software PD Mode , PD=1,			1	uA
UVLO VDD threshold	Vth_uvlo	Iout<1uA, when VDD decrease to Vth_uvlo			2.15	V
UVLO hysteresis	Vhys_uvlo			100		mV

1 2 3 4 5 6 7 8

REV.	EC#	DESCRIPTION	DATE	DRAWN	CHECKED	APPROVED
A	TJECR10018-02	NEW RELEASE PER NPRI0009	11/05/10'	RAIN	DICK, SON	HARDWARE
B	TJECR13014	AXI, AXI	05/13/13'	RAIN	SteveM eng	Jeff eng

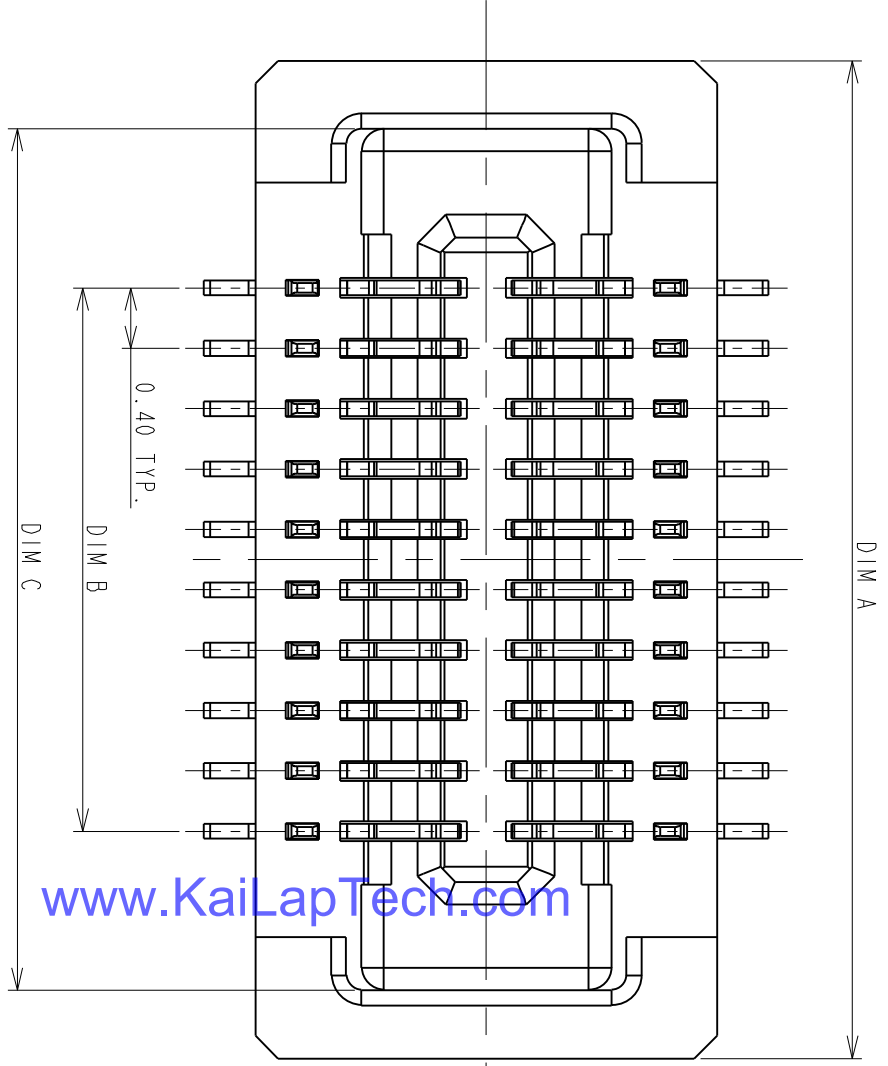

www.KaiLapTech.com

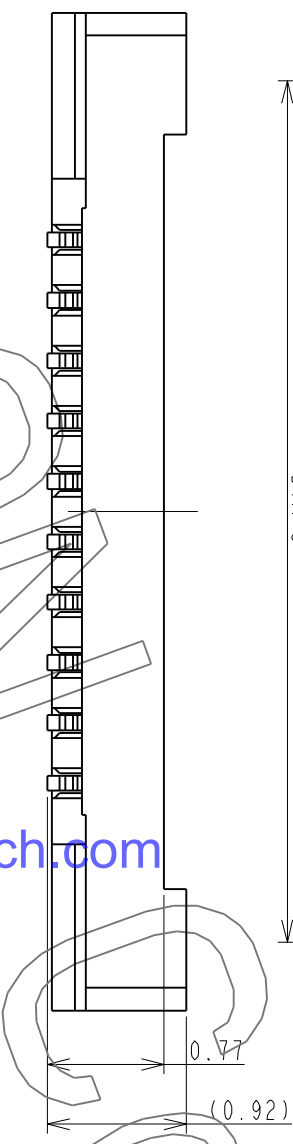

www.KaiLapTech.com

www.KaiLapTech.com

www.KaiLapTech.com

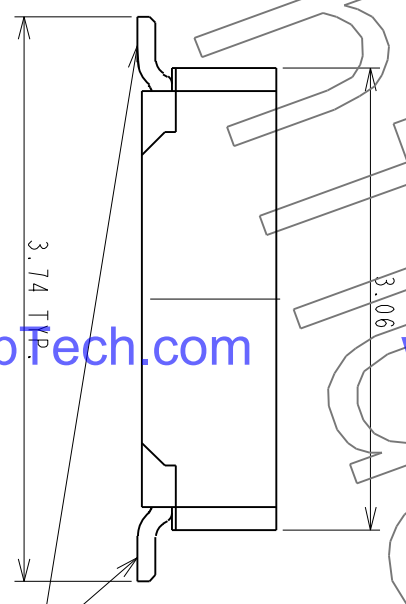

www.KaiLapTech.com

www.KaiLapTech.com

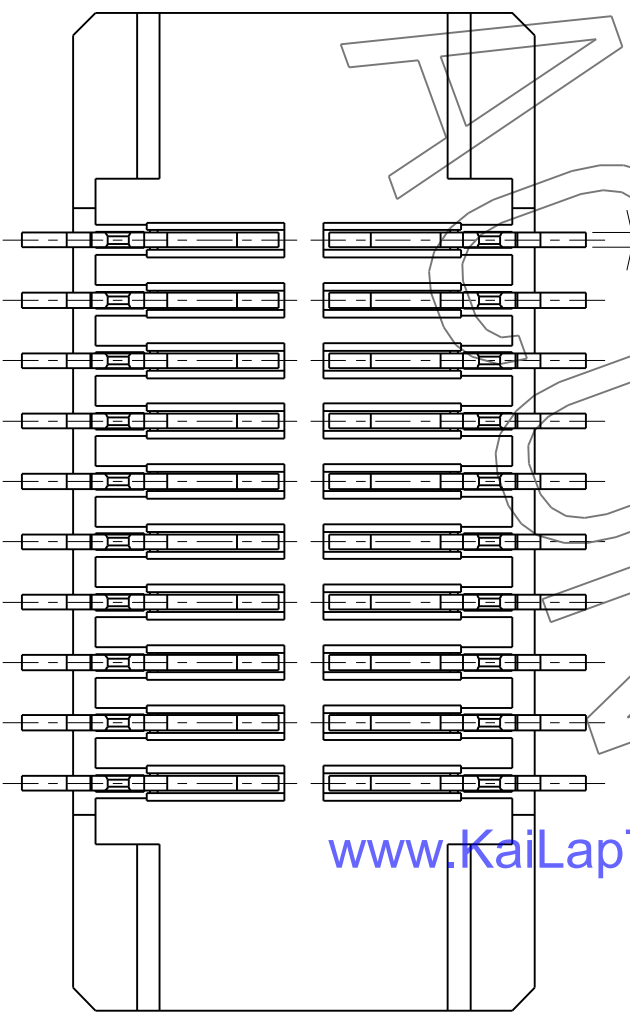
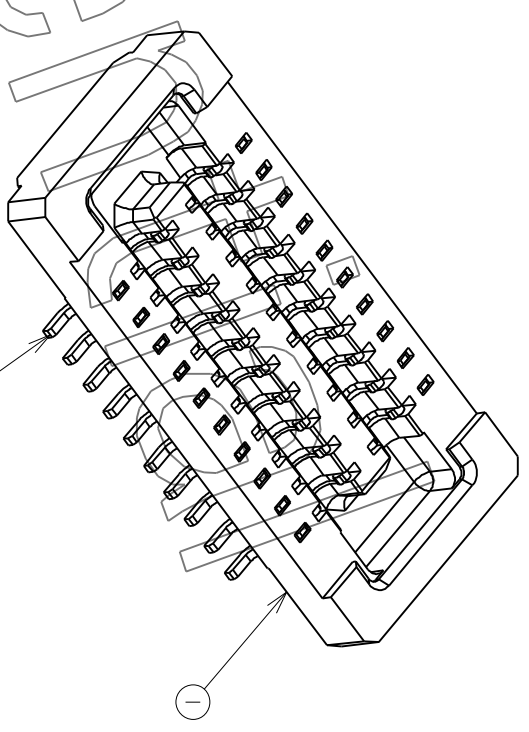

ITEM	NAME	Q'TY	PART #	MATERIAL / FINISH
2	CONTACT	XX	T-BBR43-100X30	COPPER ALLOY/PLATING GOLD
1	HOUSING	1	I-BBR43-1XXX33	HIGH TEMP RESIN/UL 94 V-0

DATE	BY	DESCRIPTION
04/15/10'	RAIN	RAIN
04/15/10'	RAIN	DESIGN
04/24/10'	RAIN	CHECKED
04/24/10'	DICK, LEE	APPROVED

TOLERANCES UNLESS OTHERWISE SPECIFIED	GENERAL X, Y, Z	±0.38
	.XX	±0.25
	.XXX	±0.05
ANGLES	X°, Y°, Z°	±3.0°
	.XX°	±1.0°
SCALE	20:1	
SHEET	1 OF 2	
UNIT	MM	

CUSTOMER DRAWING	SERIES	BBR
DWG NO. C-BBR43-04-01	SIZE	A3



P0.4*H1.0mm BOARD TO BOARD
CONN. RECEPTACLE
WITHOUT HOLD DOWN

This document and information contained herein are the property of Advanced Connectek Inc. Copies are issued in strict confidence and shall not be reproduced or copied, or used as the basis of manufacture or sale of apparatus without permission.

All materials meet the ACON's spec. environment-related substances management technical standard

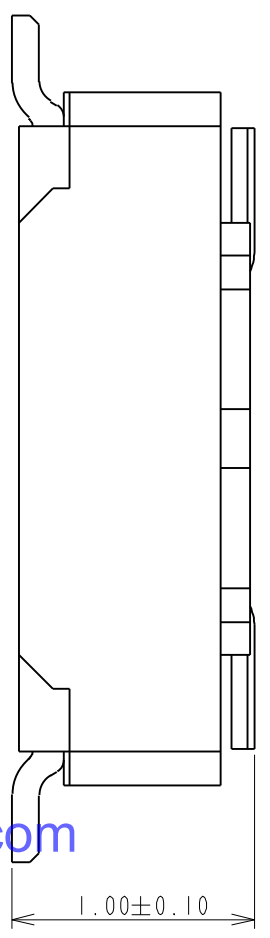

PRODUCT NUMBERING CODE:
 BBR43 - XX K X 5 X X
 1 2 3 4 5 6 7

1. PRODUCTION CODE:
 BBR43: BOARD TO BOARD 0.4 PITCH RECEPTACLE

2. POSITIONS:

XX: POSITIONS(SEE TABLE A

3. INSULATOR COLOR:

K: BLACK

4. CONTACT PLATING:

- 1: GOLD 1u" MIN
- 2: GOLD 5u" MIN
- 3: GOLD 10u" MIN
- B: GOLD 4u" MIN FOR SPOT PLATING
- ALL OVER: NI 50~100u"

5. TYPE OF HEIGHT:

5: H=0.77mm

6. TYPE OF HOLD DOWN:

3: WITHOUT HOLD DOWN

7. OTHER

- 2: WITH POST, FINISHED PRODUCTS
- 3: WITHOUT POST, FINISHED PRODUCTS

www.KaiLapTech.com

www.KaiLapTech.com

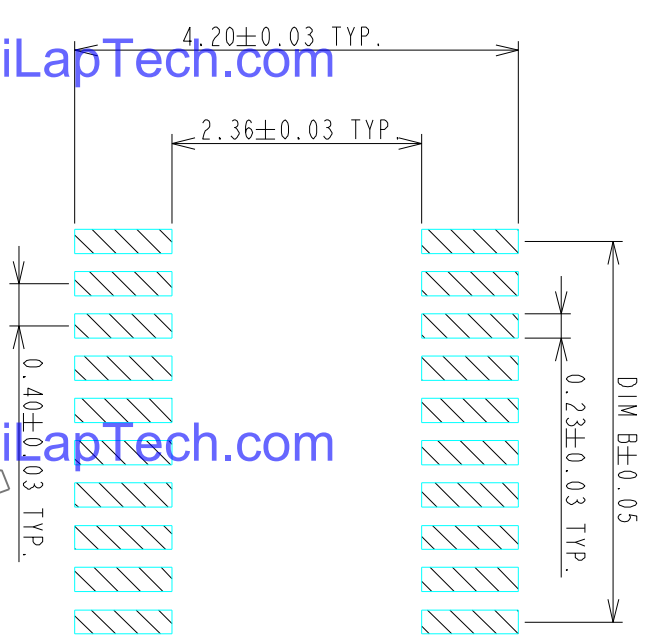

RECOMMENDED P.C. BOARD PATTERN DIMENSION (WITHOUT HOLD DOWN)

www.KaiLapTech.com

www.KaiLapTech.com

NOTES:

- 1.0: RATING
- 1.1: VOLTAGE: 60V AC/DC
- 1.2: CURRENT: 0.5 AMPS
- 1.3: OPERATION TEMPERATURE: -40°C TO +85°C
- 2.0: ELECTRICAL CHARACTERISTIC:
- 2.1: CONTACT RESISTANCE: 50 mΩ MAX INITIAL
- 2.2: INSULATION RESISTANCE: 1000 MΩ MIN INITIAL
- 2.3: DIELECTRIC WITHSTANDING VOLTAGE: 250V AC FOR ONE MINUTE
- 3.0 TOLERANCES UNLESS OTHERWISE SPECIFIED
- GENERAL: DIMENSION >10.00 ±0.13
- DIMENSION 5.00~10.00 ±0.10
- DIMENSION <5.00 ±0.05

www.KaiLapTech.com

www.KaiLapTech.com

4.0 ALL COPPLANARITY IS 0.08mm MAX. BEFORE REFLOW

ALL COPPLANARITY IS 0.10mm MAX. AFTER REFLOW

TABLE A:

POSITIONS	DIM A	DIM B	DIM C
10	4.61	1.60	3.71
14	5.41	2.40	4.51
16	5.81	2.80	4.91
18	6.21	3.20	5.31
20	6.61	3.60	5.71
22	7.01	4.00	6.11
24	7.41	4.40	6.51
26	7.81	4.80	6.91
30	8.61	5.60	7.71
32	9.01	6.00	8.11
34	9.41	6.40	8.51
40	10.61	7.60	9.71
44	11.41	8.4	10.51
48	12.21	9.20	11.31
50	12.61	9.60	11.71
54	13.41	10.40	12.51
60	14.61	11.60	13.71
70	16.61	13.60	15.71
80	18.61	15.60	17.71

www.KaiLapTech.com

www.KaiLapTech.com

TOLERANCES UNLESS OTHERWISE SPECIFIED		DRAWN		DATE
GENERAL X	±0.38	RAIN	04/15/10	
XXX	±0.13	DESIGN		
ANGLES X°	±0.13	RAIN	04/15/10	
XXX	±0.05	CHECKED		
SCALE 20:1		HARDWARE	04/24/10	
SHEET 2 OF 2		APPROVED		
UNIT mm		DICK. LEE	04/24/10	
CUSTOMER DRAWING		TITLE		
SERIES BBR		P0.4*H1.0mm BOARD TO BOARD CONN. RECEPTACLE WITHOUT HOLD DOWN		
DWG NO. C-BBR43-04-01		ADVANCED-CONNECTEK INC.		
REV. B		SIZE A3		

F

E

D

C

B

A

S5K3P8SX03

www.KaiLapTech.com **1/3.1" 16Mp CMOS Image Sensor for supporting SWDR and PD-AF Pattern** www.KaiLapTech.com

Revision 1.02

May 2016

SAMSUNG Confidential
www.KaiLapTech.com www.KaiLapTech.com
avp-electronics / cissz at 2016.06.16

Data Sheet

SAMSUNG ELECTRONICS RESERVES THE RIGHT TO CHANGE PRODUCTS, INFORMATION AND SPECIFICATIONS WITHOUT NOTICE.

www.KaiLapTech.com www.KaiLapTech.com

Products and specifications discussed herein are for reference purposes only. All information discussed herein is provided on an "AS IS" basis, without warranties of any kind.

This document and all information discussed herein remain the sole and exclusive property of Samsung Electronics. No license of any patent, copyright, mask work, trademark or any other intellectual property right is granted by one party to the other party under this document, by implication, estoppel or otherwise.

Samsung products are not intended for use in life support, critical care, medical, safety equipment, or similar applications where product failure could result in loss of life or personal or physical harm, or any military or defense application, or any governmental procurement to which special terms or provisions may apply.

For updates or additional information about Samsung products, contact your nearest Samsung office.

All brand names, trademarks and registered trademarks belong to their respective owners.

© 2016 Samsung Electronics Co., Ltd. All rights reserved.

1 Product Overview

1.1 Introduction

The S5K3P8SX is a highly integrated 16M pixel camera chip that includes a CMOS image sensor (CIS), image correction functionality and serial transmission using 4-lane MIPI. It is designed for fast yet low power operation, delivering full resolution capture at 30 frames per second (fps) and full field of view (16:9) FHD video at 60fps.

The S5K3P8SX supports Wide Dynamic Range (WDR) image capturing at both video and still modes, allowing high quality image capturing in cases of mixed lightening scenes. It also supports Phase Detection Auto Focus (PD AF) mechanism allowing efficient Auto Focus in the system.

It is fabricated by the SAMSUNG 65nm back side illumination (BSI) CMOS image sensor process developed for imaging applications to realize a high-efficiency and low-power photo sensor. The sensor consists of 4640 x 3488 effective pixels that meet with the 1/3.1-inch optical format.

The CIS has on-chip 10-bit ADC arrays to digitize the pixel output and on-chip Correlated Double Sampling (CDS) to drastically reduce Fixed Pattern Noise (FPN). It incorporates on-chip camera functions such as defect correction, exposure setting, white balance setting and image data compression.

The S5K3P8SX CIS is programmable through a CCI or SPI serial interface and includes on-chip one-time programmable (OTP) non-volatile memory (NVM).

The S5K3P8SX is suitable for a low-power camera module with a 2.8V/1.0V power supply.

www.KaiLapTech.com

www.KaiLapTech.com

1.2 Features

- 16Mp sensor with 1/3.1" optics
- Unit Pixel Size : 1.0 um
- Effective Resolution : 4640(H) x 3488(V)
- Active Resolution : 4656(H) x 3504(V)
- Color Filter : RGB Bayer Pattern
- Shutter Type : Electronic Rolling Shutter
- Max. Normal Frame Rate : 30fps@Full
- Max. Video Frame Rate : 60fps@1080p, 120fps@720p, 120fps@WVGA
- Data rate : 1500Mbps/lane
- ADC Accuracy : 10bits
- Wide Dynamic Range (WDR) image capturing support
- Phase Detection Auto Focus (PDAF) support
- PDAF tail mode support
- Interfaces :
 - Fine interface frequency control using additional dedicated PLL for EMI avoidance and integration flexibility.
 - MIPI CSI-2 four lanes (1.5Gbps per lane)
 - Output formats - RAW8 (using DPCM/PCM compression), RAW10
- Control interface :
 - I2C-compatible - Two-wire serial communication circuit up to 400 KHz
 - In Fast-mode Plus(Fm+) up to 1Mhz (External Clock >= 24Mhz)
 - SPI interface - Three-wire serial communication circuit up to 10MHz
- 32 Kbit on-chip OTP memory to support defect corrections and Chip ID
- Analog gain x16
- Vertical flip and horizontal mirror mode
- Continuous frame capture mode
- 2/2, 3/3, 4/4, 6/6 average/average-sub sampling readout
- Pixel elimination readout function
- Bad pixel correction
- Built-in test pattern generation
- Supply voltage : 2.8V for analog, 1.8V for I/O
1.0V digital core supply for normal mode
- Operating temperature : -30°C to +70°C



Referenztable für die Pinbelegungsdefinition des Kameramoduls

OmniVision Sony Himax Samsung On-Semi Aptina Himax GalaxyCore PixArt Bildsensoren	
Pin Signal	Beschreibung
DGND GND	Masse für digitale Schaltung
AGND	Masse für analoge Schaltung
PCLK DCK	DVP-PCLK-Ausgang
XCLR PWDN XSHUTDOWN STANDBY	Abschalten aktiv hoch mit internem Pulldown-Widerstand
MCLK XVCLK XCLK INCK	Systemeingangsuhr
RESET RST	Aktiv Low mit internem Pull-up-Widerstand zurücksetzen
NC NULL	keine Verbindung
SDA SIO_D SIOD	SCCB-Daten
SCL SIO_C SOIC	SCCB-Eingangstakt
VSYNC XVS FSYNC	DVP-VSYNC-Ausgang
HREF XHS	DVP-HREF-Ausgang
DOVDD	Strom für E/A-Schaltung
AFVDD	Strom für VCM-Schaltung
AVDD	Strom für analoge Schaltung
DVDD	Strom für digitale Schaltung
STROBE FSTROBE	Strobe-Ausgang
FSIN	Synchronisieren Sie das VSYNC-Signal vom anderen Sensor
SID	SCCB letzte Bit-ID-Eingabe
ILPWM	mechanische Shutter-Ausgangsanzeige
FREX	Rahmenbelichtung / mechanischer Verschluss
GPIO	Allzweckeingänge
SLASEL	I2C-Slave-Adresse auswählen
AFEN	CEN-Chip aktivieren aktiv hoch auf VCM-Treiber-IC
MIPI Schnittstelle	
MDN0 DN0 MD0N DATA_N DMO1N	MIPI 1st negative Ausgabe der Datenspur
MDP0 DP0 MD0P DATA_P DMO1P	MIPI 1st positiver Ausgang der Datenspur
MDN1 DN1 MD1N DATA2_N DMO2N	MIPI 2nd negative Ausgabe der Datenspur
MDP1 DP1 MD1P DATA2_P DMO2P	MIPI 2nd positiver Ausgang der Datenspur
MDN2 DN2 MD2N DATA3_N DMO3N	MIPI 3rd negative Ausgabe der Datenspur
MDP2 DP2 MD2P DATA3_P DMO3P	MIPI 3rd positiver Ausgang der Datenspur
MDN3 DN3 MD3N DATA4_N DMO4N	MIPI 4th negative Ausgabe der Datenspur
MDP3 DP3 MD3P DATA4_P DMO4P	MIPI 4th positiver Ausgang der Datenspur
MCN CLKN CLK_N DCKN	MIPI Uhr negativer Ausgang
MCP CLKP MCP_CLK_P DCKN	MIPI Takt positiver Ausgang
DVP Parallel Schnittstelle	
D0 DO0 Y0	DVP Datenausgabeport 0
D1 DO1 Y1	DVP Datenausgabeport 1
D2 DO2 Y2	DVP Datenausgabeport 2
D3 DO3 Y3	DVP Datenausgabeport 3
D4 DO4 Y4	DVP Datenausgabeport 4
D5 DO5 Y5	DVP Datenausgabeport 5
D6 DO6 Y6	DVP Datenausgabeport 6
D7 DO7 Y7	DVP Datenausgabeport 7
D8 DO8 Y8	DVP Datenausgabeport 8
D9 DO9 Y9	DVP Datenausgabeport 9
D10 DO10 Y10	DVP Datenausgabeport 10
D11 DO11 Y11	DVP Datenausgabeport 11



your BEST camera module partner

Kameraanwendungen



www.KaiLapTech.com

www.KaiLapTech.com



www.KaiLapTech.com

www.KaiLapTech.com



www.KaiLapTech.com

www.KaiLapTech.com





Kamera-Zuverlässigkeitstest

Reliability Inspection Item		Testmethode	Akzeptanzkriterium	
Kategorie	Artikel			
Umwelt	Lager Temperatur	Hoch 60°C 96 Std	Temperaturkammer	Keine anormale Situation
		Niedrig -20°C 96 Std	Temperaturkammer	Keine anormale Situation
	Betriebs Temperatur	Hoch 60°C 24 Std	Temperaturkammer	Keine anormale Situation
		Niedrig -20°C 24 Std	Temperaturkammer	Keine anormale Situation
	Feuchtigkeit	60°C 80% 24 Std	Temperaturkammer	Keine anormale Situation
	Thermischer Schock	Hoch 60°C 0.5 Std Niedrig -20°C 0.5 Std Radfahren rein 24 Std	Temperaturkammer	Keine anormale Situation
Physisch	Falltest (Im freien Fall)	Ohne Verpackung 60cm	10 Mal auf Holzboden	Elektrisch funktionsfähig
		Mit Paket 60cm	10 Mal auf Holzboden	Elektrisch funktionsfähig
	Vibrations Test	50Hz X-Axis 2mm 30 Minuten	Vibrationstisch	Elektrisch funktionsfähig
		50Hz Y-Axis 2mm 30 Minuten	Vibrationstisch	Elektrisch funktionsfähig
		50Hz Z-Axis 2mm 30 Minuten	Vibrationstisch	Elektrisch funktionsfähig
	Zugfestigkeit des Kabels Krafttest	Gewicht laden 4 kg 60 Sekunden Radfahren rein 24 Std	Zugprüfmaschine	Elektrisch funktionsfähig
Elektrisch	ESD-Test	Kontaktaufnahme 2 KV	ESD-Prüfmaschine	Elektrisch funktionsfähig
		Luftentladung 4 KV	ESD-Prüfmaschine	Elektrisch funktionsfähig
	Alterungstest	On/Off 30 Sekunden Radfahren rein 24 Std	Stromschalter	Elektrisch funktionsfähig
	USB-Anschluss	On/Off 250 Mal	Einstecken und ausstecken	Elektrisch funktionsfähig





Inspektionsgegenstand		Untersuchungsmethode	Inspektionsstandard	
Kategorie	Artikel			
Aussehen	FPC oder PCB	Farbe	Das bloße Auge	Größere Unterschiede sind nicht zulässig.
		Zerrissen/gehackt werden	Das bloße Auge	Das Freilegen von Kupferrissen ist nicht zulässig.
		Markierung	Das bloße Auge	Klar, erkennbar (innerhalb von 30 cm Entfernung)
	Halterin	Kratzer	Das bloße Auge	Die Freilegung von Rissen im Inneren ist nicht zulässig
		Lücke	Das bloße Auge	Erfüllen Sie den Höhenstandard
		Schraube	Das bloße Auge	Stellen Sie sicher, dass Schrauben vorhanden sind (falls vorhanden)
		Schaden	Das bloße Auge	Die Freilegung von Rissen im Inneren ist nicht zulässig
	Linse	Kratzen	Das bloße Auge	Keine Auswirkung auf den Auflösungsstandard
		Kontamination	Das bloße Auge	Keine Auswirkung auf den Auflösungsstandard
		Ölfilm	Das bloße Auge	Keine Auswirkung auf den Auflösungsstandard
Abdeckband		Das bloße Auge	Kein Problem beim Aussehen.	
Funktion	Bild	Keine Kommunikation	Testboard	Nicht erlaubt
		Helles Pixel	Tafel	Im Image Center nicht erlaubt
		Dunkles Pixel	Weißer Tafel	Im Image Center nicht erlaubt
		Verschwommen	Das bloße Auge	Nicht erlaubt
		Kein Bild	Das bloße Auge	Nicht erlaubt
		Vertikale Linie	Das bloße Auge	Nicht erlaubt
		Horizontale Linie	Das bloße Auge	Nicht erlaubt
		Kleines Leck	Das bloße Auge	Nicht erlaubt
		Blinkendes Bild	Das bloße Auge	Nicht erlaubt
		Prellung	Inspektionslehre	Nicht erlaubt
		Auflösung	Diagramm	Folgt dem Diagrammstandard für ausgehende Inspektionen
		Farbe	Das bloße Auge	Kein Problem
		Lärm	Das bloße Auge	Nicht erlaubt
		Ecke dunkel	Das bloße Auge	Weniger als 100 x 100 Pixel
Farbauflösung	Das bloße Auge	Kein Problem		
Abmessungen	Höhe	Das bloße Auge	Befolgt Zulassungsdatenblatt	
	Breite	Das bloße Auge	Befolgt Zulassungsdatenblatt	
	Länge	Das bloße Auge	Befolgt Zulassungsdatenblatt	
	Gesamt	Das bloße Auge	Befolgt Zulassungsdatenblatt	



KLT-Paketlösungen

KLT Kameramodul



Komplett mit Linsenschutzfolie



Tablett mit Gitter und Raum



Legen Sie die Kameras auf das Tablett



Paketlösung für Kameramodule

Volles Tablett mit Cameras



Abdeckschale mit Deckel



In Antistatikbeutel stecken



Staubsaugen Sie den antistatischen Beutel





Paketlösung für Kameramodule

Versiegelter Vakuumbbeutel mit Etiketten

1. Modell und Beschreibung 2. Menge 3. Versanddatum 4. Achtung





Paketlösung für große Bestellungen

Schaumstoffplatten zwischen
die Tablettts legen



Schaumstoffplatten sind etwas
größer als Tablettts



www.KaiLapTech.com

Legen Sie Schaumstoffplatten und
Tablettts in die Schachtel



www.KaiLapTech.com

Schaumstoffplatten sind eng anliegende Box





Paketlösung für kleine Bestellungen

Legen Sie die Schaumstoffplatten und Tablett in die kleine Schachtel



Schaumstoffplatten passen gut in die kleine Box



www.KaiLapTech.com

Paket in kleiner Box für den Versand

Legen Sie kleine Kartons in größere Kartons



Carbon Box Paketlösung

Verschließen Sie die Carbonbox

Beschriftete Schachtel mit Endverpackung



Versandfertige Karbonbox

1. Lieferadresse und Telefonnummer
2. Box-Nr. und Versanddatum
3. Zerbrechliche Vorsicht



Lösung für Musterbestellungspakete

Legen Sie die Probe in einen kleinen antistatischen Beutel



Stecken Sie die Anschlüsse in den kleinen antistatischen Beutel



Musteretiketten auf dem kleinen Beutel

1. Kameramodul oder Anschlussmodell 2. Lieferdatum und Menge 3. Achtung





Steckverbinder Paketlösung für große Bestellungen

Steckverbinder in einem Rad



Steckverbinder im Rad beschriftet



Das Rad passt perfekt in die Box



Steckerbox versandfertig



Unternehmen Kai Lap Technologies (KLT)

Kai Lap Technologies Group Limited. (KLT) wurde 2009 gegründet und ist ein technologiegetriebener Hersteller der nächsten Generation, der sich auf Forschung, Design und Produktion von Audio- und Videoprodukten spezialisiert hat. KLT verfügt über 20.000 Quadratfuß automatisierte Fabriken mit 100 Mitarbeitern und einem jährlichen Durchsatz von 30.000.000 Kameraeinheiten.

KLT bietet OEM-, ODM-Design, Auftragsfertigung und baut die Kameraprodukte. Sie können uns die Anforderungen auch mit einem Handentwurf übermitteln, unser Vertrieb und unsere Technik arbeiten zusammen, um Ihre Anforderungen zu erfüllen. Wir verstehen uns als Ihr langfristiger Partner bei der Entwicklung praktischer und innovativer Lösungen.

Unser Team deckt alles von der ersten Konzeptentwicklung bis zum Massenprodukt ab. KLT ist spezialisiert auf kundenspezifisches Kameradesign, Rohmaterial, Elektrotechnik, Firmware-/Softwareentwicklung, Produkttests und Verpackungsdesign. Unsere erfahrenen strategischen Versorgungssysteme bieten eine robuste und zuverlässige Fertigungskapazität für Aufträge unterschiedlicher Größe.

www.KaiLapTech.comwww.KaiLapTech.com**Eingeschränkte Garantie**

KLT gewährt die folgende eingeschränkte Garantie, wenn Sie das/die Produkt(e) direkt von der Firma KLT oder von der Website von KLT, www.KaiLapTech.com, gekauft haben. Produkte, die von anderen Verkäufern oder Quellen gekauft wurden, fallen nicht unter diese beschränkte Garantie. KLT garantiert, dass das/die Produkt(e) bei normalem Gebrauch für einen Zeitraum von einem (1) Jahr ab dem Datum, an dem Sie das Produkt erhalten („Garanzzeitraum“), frei von Material- und Verarbeitungsfehlern sind.

Für alle Produkte, die während des Garanzzeitraums Material- oder Verarbeitungsfehler enthalten oder entwickeln, wird KLT nach eigenem Ermessen entweder: (i) die Produkte reparieren; (ii) das/die Produkt(e) durch ein neues oder generalüberholtes Produkt(e) ersetzen (Ersatzprodukt(e) sind von identischem Modell oder funktionell gleichwertig); oder (iii) Ihnen den Preis erstatten, den Sie für das/die Produkt(e) gezahlt haben.

Diese eingeschränkte Garantie von KLT ist ausschließlich auf Reparatur und/oder Ersatz zu den oben genannten Bedingungen beschränkt. KLT ist nicht zuverlässig oder verantwortlich für nachfolgende Ereignisse.





CMOS CAMERA MODULES



your BEST camera module partner

KLT Stärke

Leistungsstarke Fabrik



www.KaiLapTech.com

www.KaiLapTech.com

Professioneller Service



www.KaiLapTech.com

www.KaiLapTech.com

Versprochene Lieferung



www.KaiLapTech.com

www.KaiLapTech.com



www.KaiLapTech.com sales@KaiLapTech.com Tel: (852) 6908 1256 Fax: (852) 3017 6778

All rights reserved @ Kai Lap Technologies Group Ltd. Specifications subject to change without notice.